

# Chapter 20- Creating Springs, Screws and Gears

## Duplicating Meshes to Create Screws and Gears

So far, we see that Blender has many features that are found in almost all 3D computer programs like the ability to extrude along paths, subtract and add meshes through boolean expressions and now we will examine **revolving-type** commands. The commands used for these effects are found in the *Edit Buttons* and are visible when in *Edit Mode*. The process to get them to work can be confusing to beginners. Here's what you see:

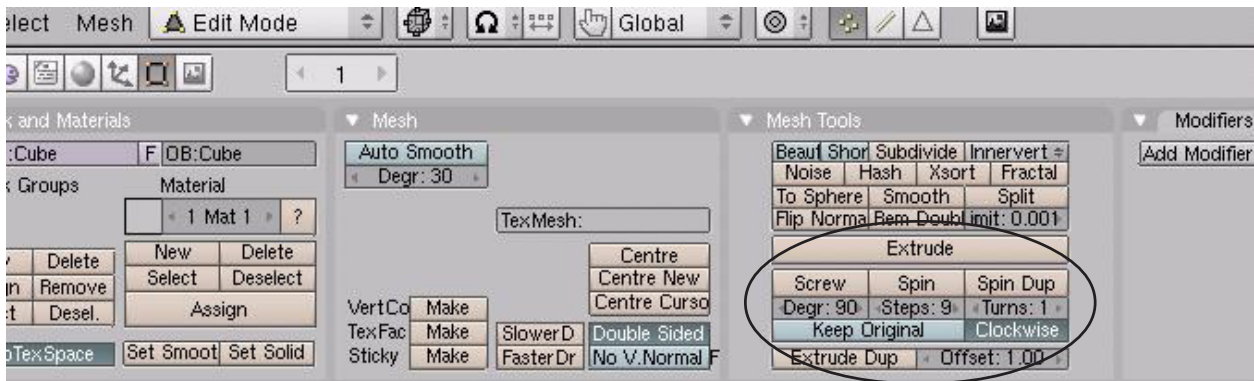

### Spin Duplicate

Spin Duplicate will take a group of vertices and copy them around the *3D Cursor* location. For our example, I will use a modified cube to make a gear. Step 1 is to shape a cube into a simple gear tooth in edit mode. While in edit mode, select all vertices and review the following settings:

*Cube shaped into simplified gear tooth*

**At time, you will get a question mark by your cursor when you use these commands. Just click in the 3D window to see the results.**

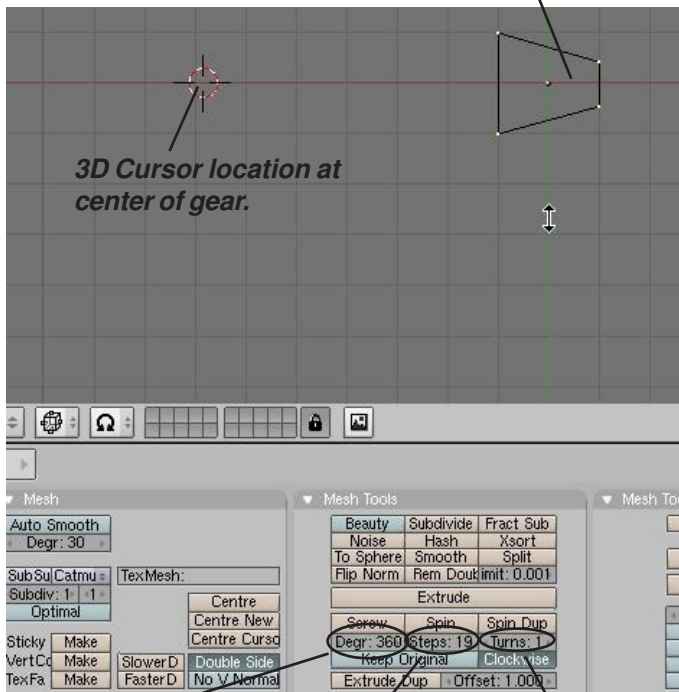

*3D Cursor location at center of gear.*

**Degrees to go around-** set to 360 for a full circle

**Steps-** number of instances. In our case number of gear teeth.

**Turns-** how many times to go around. We only want 1 turn for a gear.

With all vertices selected and everything set to these numbers, hit the "**Spin Dup**" button and see the results. You will need to experiment with sizes and number of steps to get a good gear without any overlaps. Remember that edit mode has an **Undo command**. If it isn't right, just hit "**Ctrl-Z**" and it will go back to your one gear tooth. Make sure all vertices are still selected and try again with some different settings. To fill in the gear and make it look realistic, add some cylinders to fill it in. You can also add a nice touch by using **Boolean Difference** to cut holes in the body of the gear.

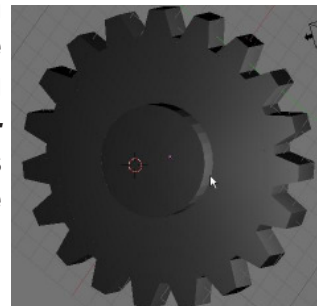

## Chapter 20- Creating Springs, Screws and Gears

### Spin

The *Spin* command operates similar to the *Spin Duplicate* command, except that it works more like a **revolve-extrude** command. You can take a plane or a circle, shape it, then revolve it around the *3D Cursor location*. For our example, we started with a **Mesh Circle** in the **Top View**, then we placed the 3D Cursor at a desired location. Enter *edit mode* and select all vertices. Switch to the **Front View** and select the “**Spin**” command in the edit buttons. Notice how far it extrudes and the number of steps. **Undo** (“Ctrl-Z”) the spin so you’re back to your basic shape again and change **degrees to 360 and steps to 30**. Make sure all vertices are selected and try again. Here’s our results:

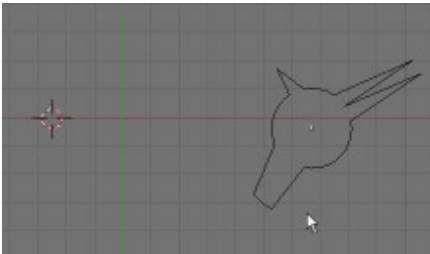

Circle that has been shaped in edit mode. 3D Cursor to left of shape for center point.

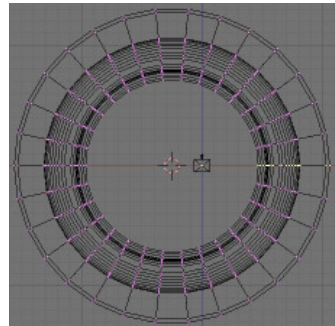

All vertices selected, switched to frontal view and spin command used.

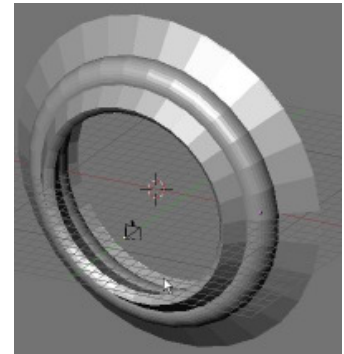

Final results of Spin command

### Using Mesh Editing to Create Helix Shapes

This is the most complex of the 3 tools. This tool can be used to represent any type of **helix object**. Springs, threads on a bolt, worm gears, etc. can be done with a little work once you know how to use it. The Screw command only works in the **Front View** (number pad 1) so switch to the front view to develop a spring.

In order to create a spring, you need to start with a **Mesh Circle** in the front view. Like the other spin tools, you need to place the *3D Cursor* in the location where you want the center to be located. **Now you need to create a line that will represent the spacing in the turns** (for threads on a bolt, the line is short so the threads are close together, for a spring with a large space between loops, draw a longer line). To create the line, add a **Mesh Plane** to your scene and delete 2 of the vertices. Size the line that is left to what you need for your model. **Join the line and the circle together so that it is one object**. For the best results, *place the line you created in the center of the revolved mesh* (beside your 3D Cursor). The vertices can be moved or adjusted in edit mode. Here’s an example of your model:

Here are the 2 vertices that form the line to controls spacing

3D Cursor location

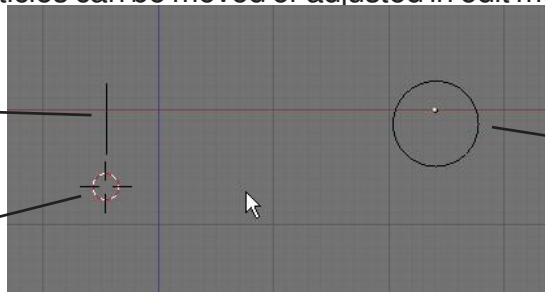

Circle that forms profile of the spring. Any shape can be used.

## Chapter 20- Creating Springs, Screws and Gears

Set the **Degrees** to 360, **Steps to 16 or higher** (depending on the smoothness you want) and **Turns** to how many loops you want (I'll set it to 8). Select **All** vertices (including the 2 that form the line) and select the **Screw** button. You should see a spring on your screen. If something needs adjusting, press "**Ctrl-Z**" to undo in edit mode to go back to your basic shape and try again. Here's our results:

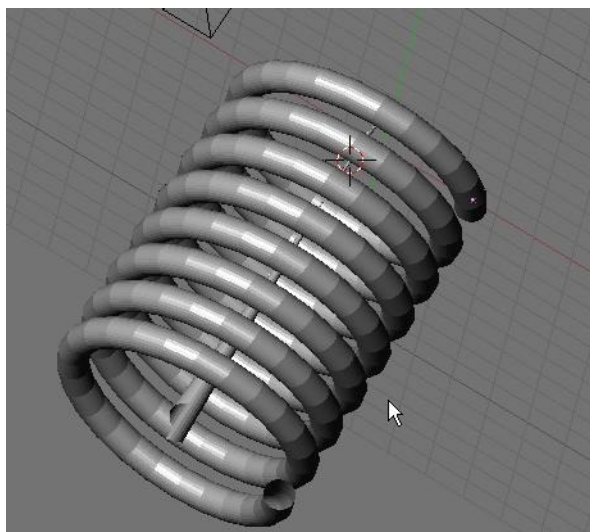

You will notice a shape in the middle of your spring. That shape is created from the vertices you used to designate the length of each loop. You placed this shape in the middle so it is easier for you to select these vertices in edit mode and



erase them. Switch to a top view and enter edit mode. Select the vertices and hit "**Delete**". Now you'll just have your spring on the screen.

### Other Shapes:

Here's how you can create some other things:

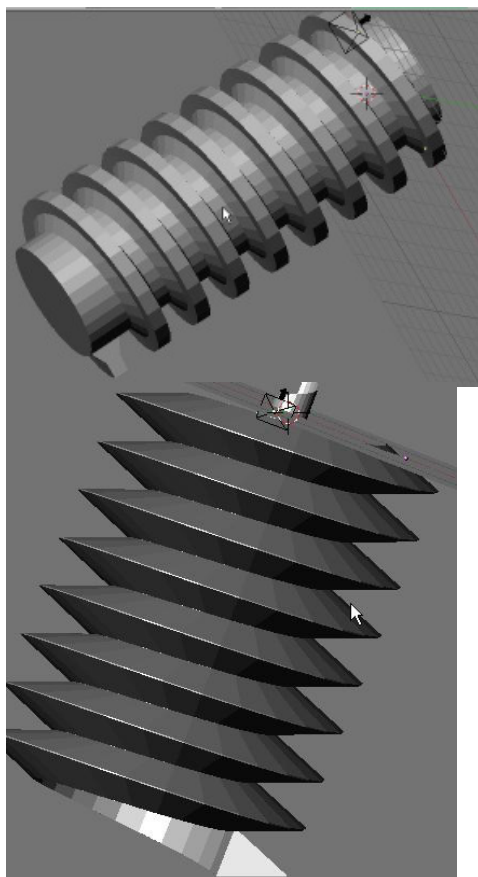

*A Worm Gear created using a subdivided plane as the profile and the line set to equal twice the height of the gear profile. A cylinder has been added through the center to give it a solid appearance.*

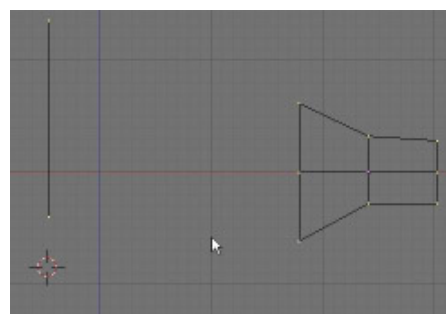

*Bolt and screw threads can be created with a plane shaped into a triangle and the line for spacing set to exactly the same length as the base of the triangle. To make a pointed screw, grab the end thread vertices and scale it with proportional vertex editing ("O") for a nice look.*

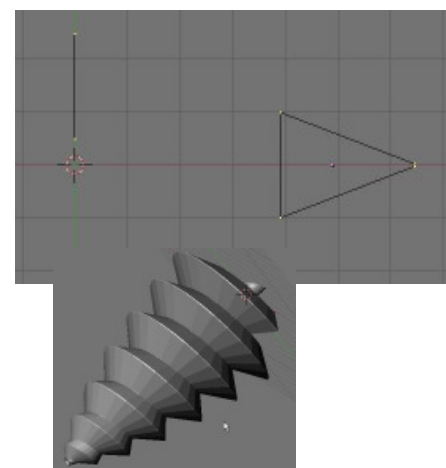

## Gear Design Practice Exercise

Create a worm gear and a spur gear to mesh with each other using the information discussed in this chapter. Add materials, textures and appropriate lighting. **Make a 200 frame animation of the gears turning.** Try to make them mesh perfectly! Remember the Extend Mode options available in the **IPO Window**. All you need to do is create a small section of the animation and let the computer do the rest!

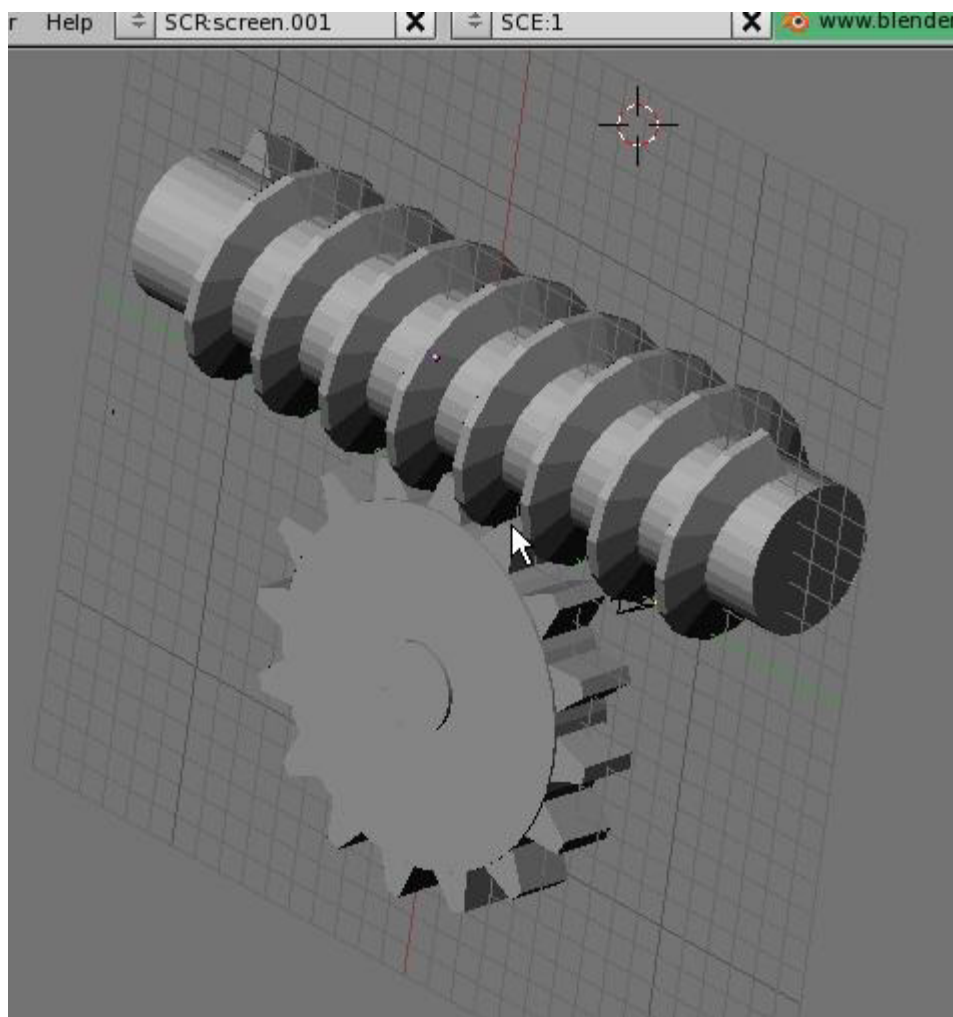

**\*\* Call the instructor when finished\*\***